



# DIAPHRAGM VALVE



## DESCRIPTION

DESIGN AND MANUFACTURE CONFIRM TO BS5156

### WORKING PRESSURE

DN50-DN100: 1.0 Mpa  
DN125 -DN150: 0.6 Mpa  
DN200-DN300: 0.35 Mpa

FLANGE DIMENSIONS CONFIRM TO Bs4504 PN10

## MATERIALS

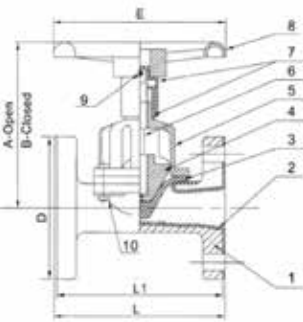

NO.	PART	MATERIAL
1	BODY	GG25
2	BODY LINED	NATURAL RUBBER
3	DIAPHRAGM	NATURAL RUBBER
4	VALVE CLACK	GG25
5	BONNET	GG25
6	STEM	STAINLESS STEEL
7	BUSH	PLASTIC
8	HANDWHEEL	GGG40
9	PIN	CARBON STEEL
10	BOLT	STAINLESS STEEL

## DIMENSION (MM)

DN	L	L1	A	B	D	E
50	194	190	185	165	165	160
65	222	216	224	200	185	200
80	258	254	273	240	198	250
100	309	305	321	285	220	315
125	362	356	347	305	250	315
150	412	406	447	385	283	400
200	527	521	-	415	335	500
250	640	635	-	560	400	500
300	755	749	-	640	460	630