

Wear part		
Pos	Q.ty	Description
11	1	High speed shaft oil seal
13	1	High speed shaft bearing
14	1	High speed shaft bearing
17	2	Low speed shaft oil seals
16	2	Low speed shaft bearings
	1	Lip seal -L

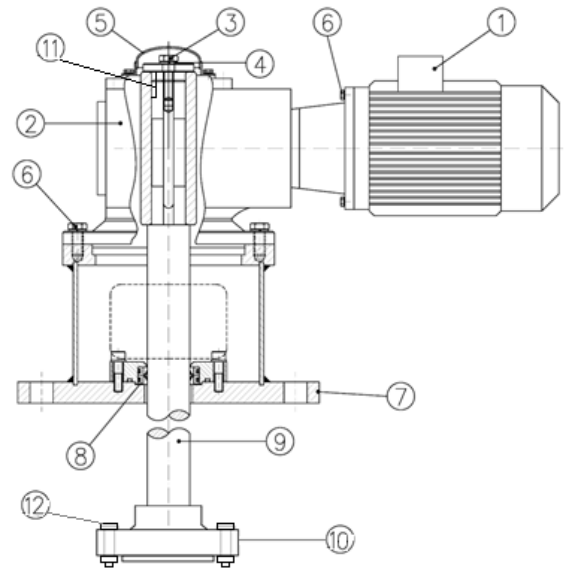

AVF-L	
Pos	Description
1	Electric Motor
2	Gearbox
3	Fixing screw
4	Washer
5	Protection
6	Fixing screw
7	Connecting Flange
8	Lip seal
9	Shaft
10	Impeller
11	Impeller fastener
12	Key

AVF-S	
Pos	Description
1	Electric Motor
2	Gearbox
3	Fixing screw
4	Washer
5	Protection
6	Stool
7	Connecting Flange
8	Cartridge seal
9	Shaft
10	Flanged coupling
11	Key
12	Fixing Screw